

# matki | S H O W E R I N G

## SQUARE WALK-IN DUAL CONTROL THERMOSTATIC SHOWER MIXER\* FOR SERIES WSD/WRD/WSF,

\*Patent applied for

INSTALLATION

PARTS LIST

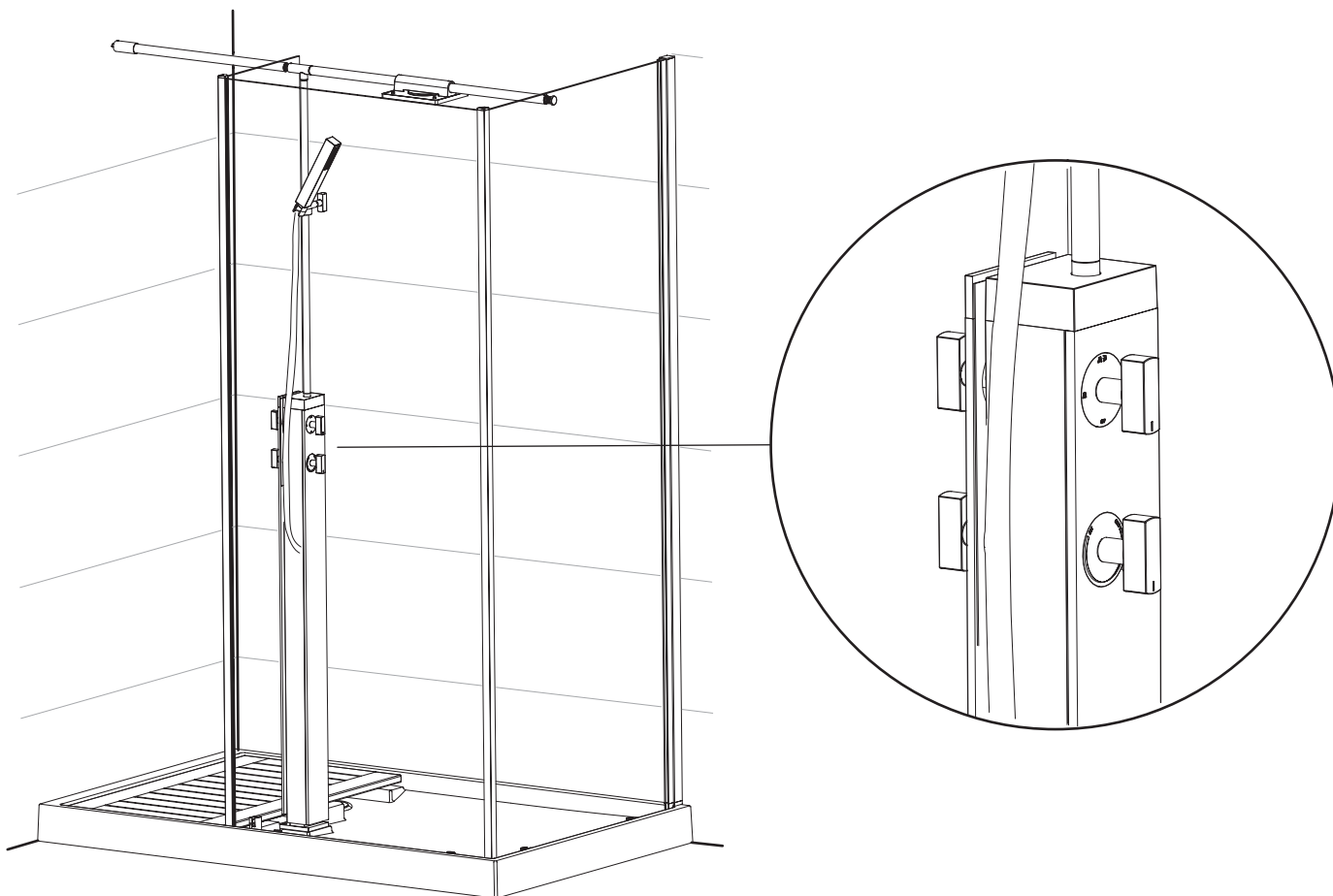

**MATKI PLC, CHURCHWARD ROAD, YATE, BRISTOL, BS37 5PL**  
TELEPHONE:01454 328816 (AFTER SALES) FAX:01454 328821 EMAIL: techsupport@matki.co.uk

# 1.IMPORTANT

Before disposing of the carton and/or commencing assembly, please check all the parts to ascertain that none are missing and they are all undamaged. No claim for missing/damaged parts will be accepted once the packing carton has been disposed of and/or assembly has commenced. In case of query contact your Stockist with details of model number, finish and serial number.

**Please read complete installation instructions before fitting.**

## Specification.

The shower mixer will operate correctly with water pressures between 0.1 bar to 5 bar.

For pressures above 5 bar fit pressure reducers. The valve is suitable for standing water pressures up to 9 bar.

Optimum performance when inlet pressures are nominally balanced to within 10% of each other during flow.

Optimum performance is obtained when water **temperature differentials of 20°C** or more exist between hot and cold. Temperature accuracy will be reduced at temperature differentials below **12°C**.

Recommended minimum Cold Water supply temperature: 3°C.

Recommended Maximum Hot Water supply Temperature 60-65°C.

The shower mixer can accept temporary elevated temperatures to 85°C without damage for reasons of general safety,

Hot water storage temperatures should be maintained between 60-65°C.

The valve is suitable for all water systems including

Gravity fed

Pumped Systems

Combination Boilers

Condensing Boilers

Mains Pressure fed Systems

**Fit isolation valves to both HOT and COLD inlet supplies.**

**Most problems with any thermostatic shower mixer are caused by debris from new pipework getting into the thermostat when it is first installed. It is important to flush out all new pipework before commissioning.**

# CONFIGURATION

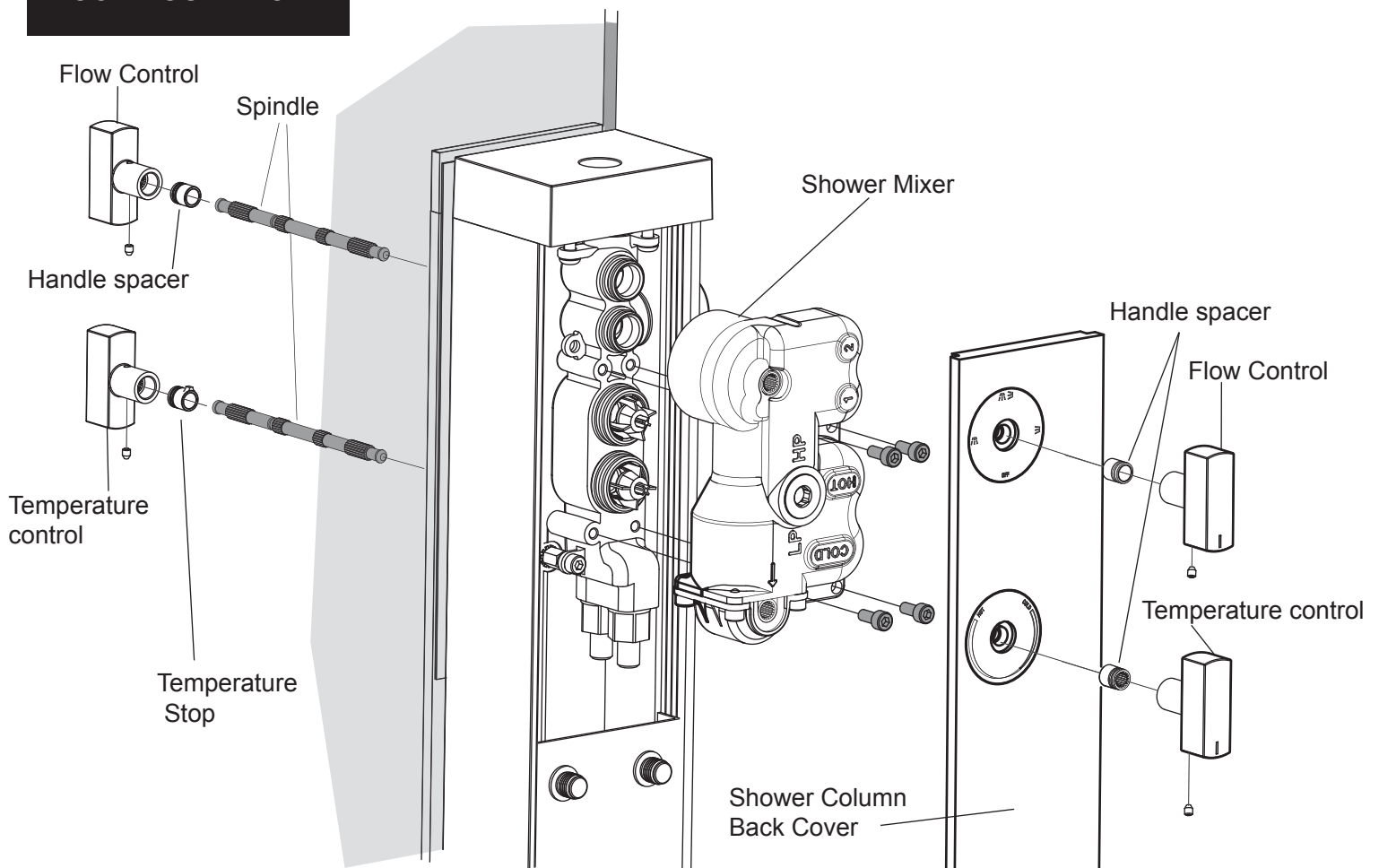

## 2. OPERATION

### TEMPERATURE CONTROL

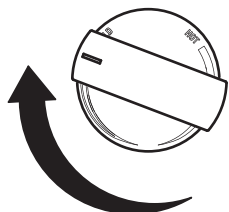

ROTATE CLOCKWISE FOR COLD

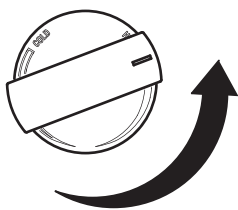

ROTATE ANTICLOCKWISE FOR HOT

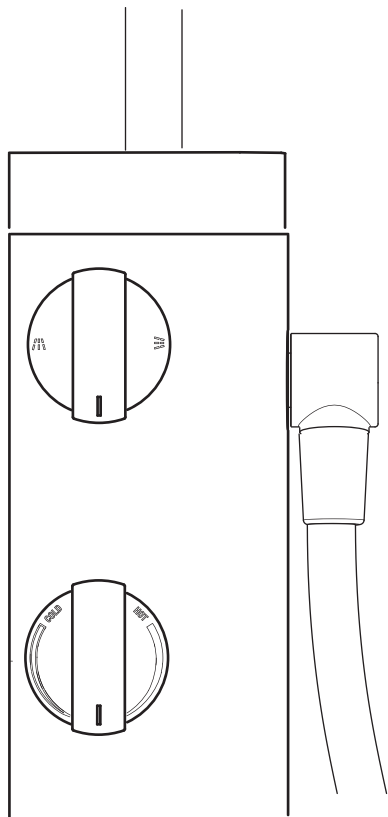

### FLOW CONTROL

#### OVERHEAD DELUGE

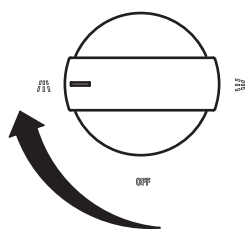

#### HAND SHOWER

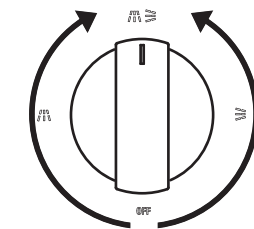
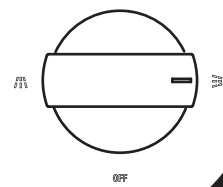

#### BOTH OVERHEAD AND HAND SHOWER

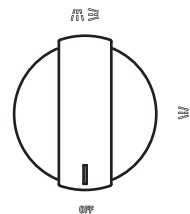

#### OFF

## 3. FITTING MIXER

(a)

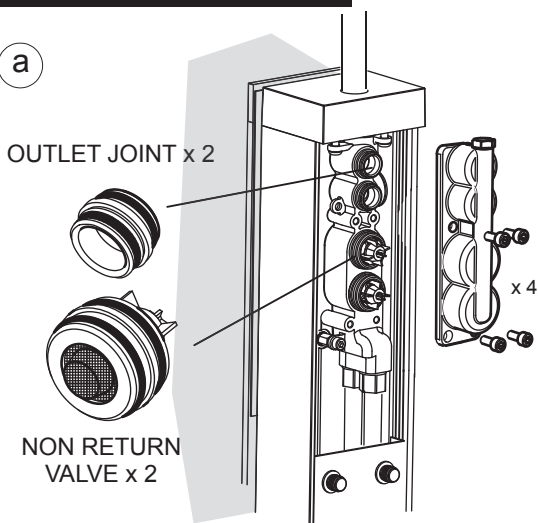

(b)

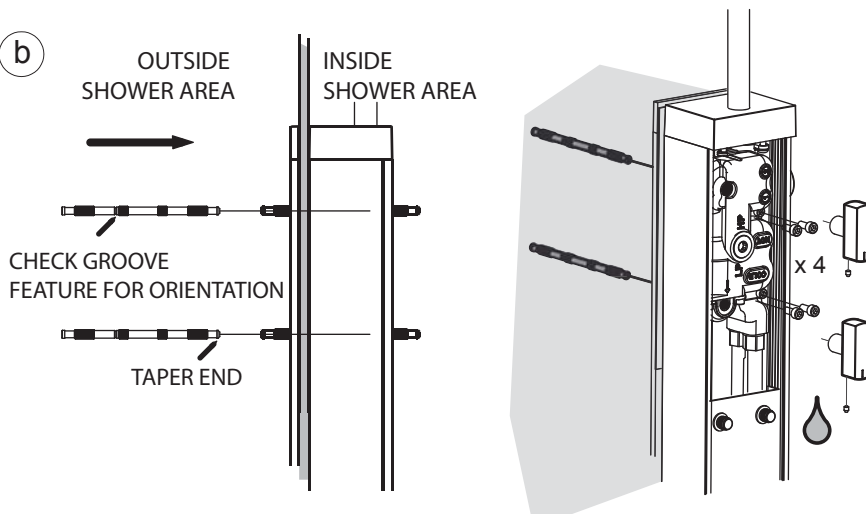

**Before fitting the Shower Mixer turn off the hot and cold inlet supplies.** Remove the Plumb Check cover plate by unscrewing the 4 x M5 x 12 socket cap screws from the manifold with the allen key supplied (kit of parts), these screws are also used for fitting the shower mixer **(a)**. There will be some water still retained in the system from flushing the pipework which will briefly flow until drained. Dry the area before fitting the shower mixer. Remove the hot and cold Non return valves from the manifold, check for debris from flushing the pipework on the gauze filter on the bottom of the non return valves. Clean if required and refit the non return valves into the Manifold **(a)**. **Important, refit the non return valves with the gauze filter facing down into the manifold.** When removing the Plumb check cover the non return valves and outlet joints may be retained in the Plumb Check cover, remove them and refit them into the Manifold before fitting the shower mixer. We advise that you keep the Plumb Check cover as it could be used again in a maintenance situation.

Push fit the Shower Mixer onto the Manifold and onto the Inlet and Outlet joints **(b)**. Secure the Shower mixer with the 4 x M5 x 12 socket cap screws used to fit the Plumb check cover. Turn on the water supplies. Fit the Spindles and handles **temporarily** into the shower mixer as shown from the front face of the column, the Spindles have a groove feature at one end, this engages into the Column assembly to hold the spindles to the correct depth in the Mixer body. Carefully push the Spindles into the Mixer body ensuring that they are aligned with the spline in the Flow and Temperature control cartridges **(b)**

1. Test the operation of the flow control to the outlet(s).
2. Test the operation of the temperature control from hot to cold.
3. Check the Inlet and Outlet joints between the Manifold and Mixer for leakage. See Trouble Shooting, if required.

## 4.FITTING COLUMN BACK COVER

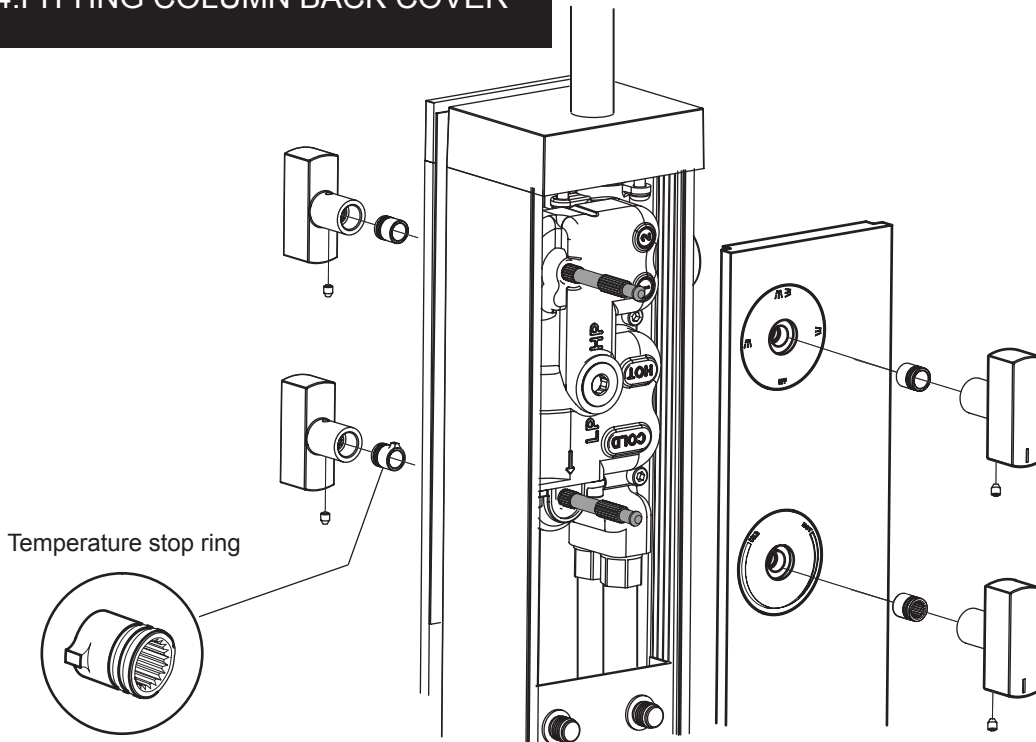

Remove the Handles. Fit the Shower column back cover as shown in the installation instructions. Check that the spindles protrude equally from the inside and outside face of the column and align through the holes. The spindles can be removed by pushing them through the column and pulling them from the inside.

**Important, do not remove the spindles by pulling from the outside of the column.**

Fit the handle spacers to both sides of the Flow control spindle. Fit one spacer to the outside of the Temperature control. Fit the Temperature stop ring (**only**) on the outside of the Temperature control spindle. (See setting temperature below) Align the handles opposite each other with the graphic line on the handles to the off position on the flow control and to full cold on the temperature control.

## SETTING TEMPERATURE

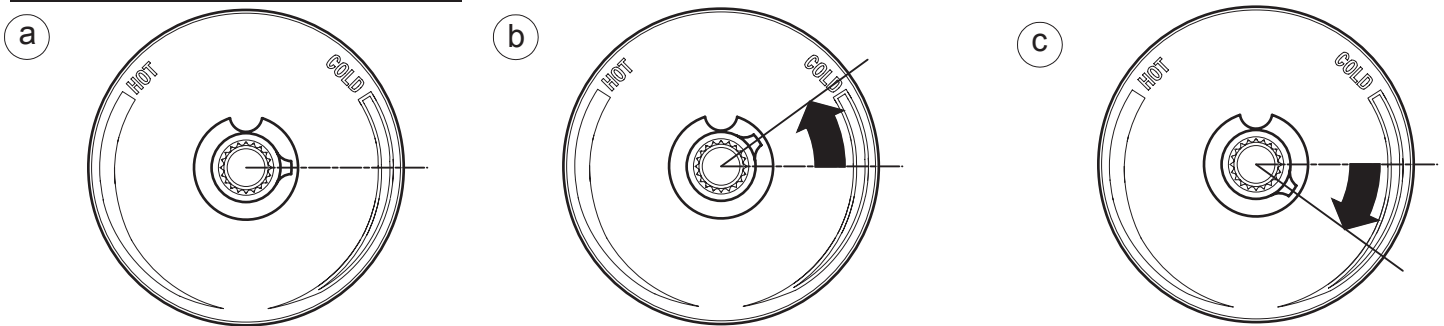

**Important : The maximum hot water temperature must be checked and reset if necessary, prior to the mixer being commissioned to avoid scalding. Check that the hot water system is operational and that the hot water supply has reached the optimum temperature.**

The temperature control handle has a separate temperature stop ring which is fitted under the handle on the spindle. Firstly remove the temperature stop ring to set the maximum temperature. The recommended **maximum** hot water temperature from the mixer should not exceed **42 °C**. Temporarily fit the handle back on the temperature control spindle, rotate to the full cold position and remove the handle. As a guide refit the temperature stop ring onto the handle spindle in the position shown relative to full cold.(a) In optimum operating conditions this should be approximately 42 °C, however this position may vary due to fluctuating hot and cold supply inlet temperatures. Test the mixer for correct thermostatic operation check the maximum temperature with a thermometer and adjust the position of the temperature stop ring as required before securing the handle. **To increase the maximum hot temperature**, fit the stop ring on the spindle spline closer to cold. **(b) To decrease the maximum hot temperature**, fit the stop ring on the spindle spline closer to hot **(c)**

When the correct maximum temperature is set, fit the handle with the graphic line on the handle face aligned to the full **cold** position. Turn the flow control to off. There is a handle spacer under this handle, fit this handle with the graphic line on the handle face aligned to the **off** position.

## 5. TROUBLE SHOOTING

### Visual check

1. **Fault:- Water leaking between Mixer and manifold.**  
Inlet or outlet joints not seated correctly in manifold o-rings not squeezed into inlet or outlet evenly.  
Damaged o-rings on inlet or outlet joints in manifold - Replace with spare o-rings supplied in the kit of parts.
2. **Fault:- Water leaking from centre of flow control on mixer.**  
Fault in Diverter Cartridge, replace Diverter Cartridge. (see 6.Maintenance)
3. **Fault:- Water leaking from temperature control on mixer.** See 6. Maintenance
4. **Fault:- Water leaking from mixer casting.** Replace mixer.

### Shower Mixer Performance

5. **Fault:- No mixed water to the outlets when turning on the flow control.**  
Non return valves fitted upside down in the wall box manifold. See 3. Fitting Mixer.
6. **Fault:- Shower runs Hot when turned to cold, and Cold when turned to hot**  
Hot and cold inlet tubes plumbed incorrectly. Check Hot and Cold inlets pipes are fitted into correct inlets on Manifold.
7. **Fault:- Shower will not run hot when first installed.**  
Setting the Temperature. See 4.
8. **Fault:- Shower only runs cold or luke warm when first installed.**  
Thermostat may have debris trapped in COLD side of thermostat. See Maintenance.  
Fault with thermostatic element. Replace with new thermostatic element.
9. **Fault:- Shower only runs HOT.**  
Thermostat may have debris trapped in HOT side of thermostat. See Maintenance.  
Fault with thermostatic element. Replace with new thermostatic element.
10. **Fault:- Cold water cross tracking through valve into hot water system.**  
Non return valves / may need cleaning or replacement. See 6. Maintenance.
11. **Fault:- Shower lets by or constant drips.**  
Diverter cartridge may need replacing, diverter cartridge clamp nut has not been fully tightened .  
See Operation, Converting Diverter Cartridge or 6.Maintenance.
12. **Fault:- Very low flow or no flow, gravity fed installations.**  
No pressure due to very low pressure or blocked filters or pipework.
13. **Fault:- No or very little flow, pump fed installations.**  
Flow rate may be insufficient to activate booster pump flow switches.

### Operation

14. **Fault:- Hot and cold icons opposite on Controls discs .**  
Remove handles and Valve and loosen the grub screws on the inside of the Column extrusion and Shower column front panel.  
Remove discs and swap discs from front to back. Retighten grub screws.

**Please see Parts list, to identify parts and part numbers for replacement items.**

## 6.MAINTENANCE

TOP FACE

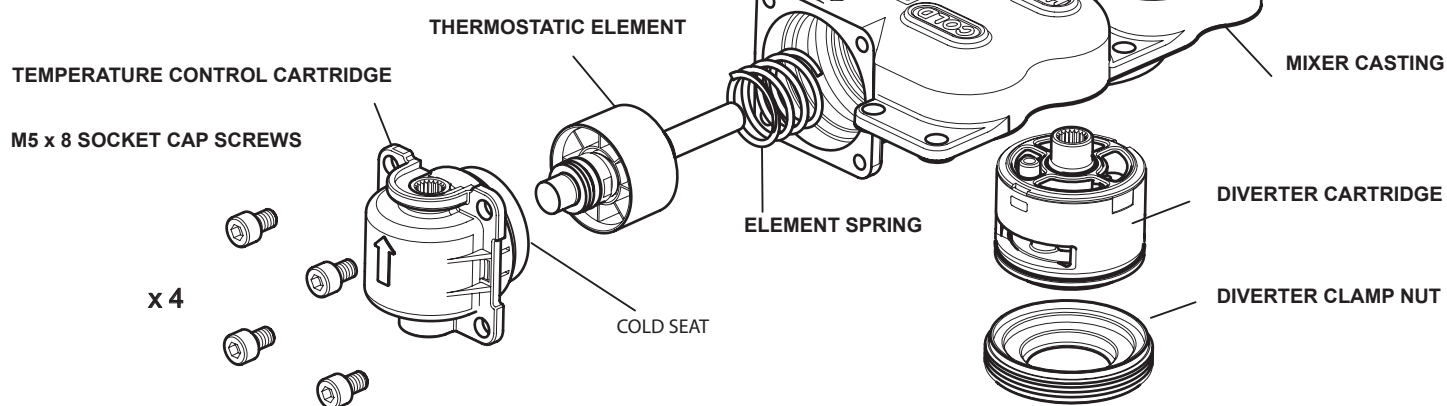

a

TEMPEROSTATIC ELEMENT

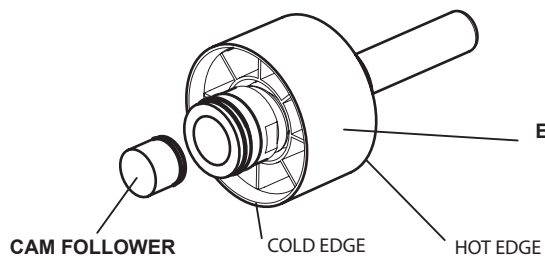

b

DIVERTER CARTRIDGE POSITION

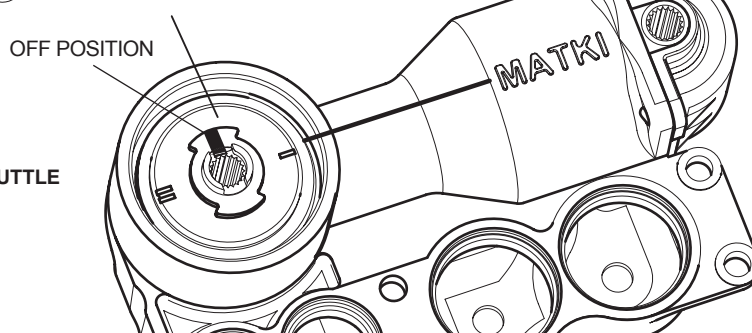

**IMPORTANT. Before commencing maintenance on the mixer turn off the hot and cold inlet supplies. When maintenance is complete ensure that the mixer is checked and fully commissioned before use.**

Remove the Mixer cover plate and unscrew the M5 x 12 socket cap screws to remove the mixer from the manifold.

**NON RETURN VALVES.** (See Fitting Mixer 3.)

**Fault 1.** Damaged o-rings on non return valve. Replace with part 1602 AF (supplied in the kit of parts SB 2/5245).

**Fault 10.** Remove and clean any debris and limescale from the gauze filter on the bottom of the part. Clean the non return valves by depressing the plunger and blowing through and refit, or replace with new non return valve part SB 2/5230

**SHOWER MIXER PERFORMANCE** (Please see Trouble Shooting for fault references).

**Fault 8.**

Remove the mixer as above and carefully remove the M5 x 8 socket cap screws from the black temperature control cartridge on the mixer body to access the thermostatic element.

The black temperature control cartridge has a rubber seat on the bottom face which is the cold seat.

Check for limescale or debris on this seat remove all traces of debris and de-scale as required using a proprietary de-scaler. Check for limescale on the cold edge of the thermostatic element shuttle, descale as required.

**Fault 9.**

The hot seat is located inside the mixer casting check for traces of debris on this seat and on the hot edge of the Thermostatic element shuttle. (a) Flush out the mixer body to remove any debris and de-scale the shuttle as above. Alternatively if faults 8 & 9 are not resolved replace with a new thermostatic element assembly SB 2/5211.

Important, on refitting the thermostatic element assembly remember to fit the element spring into the mixer first then the thermostatic element ensuring that the cam follower is positioned in the end of the thermostatic element.

Refit the temperature control cartridge with the arrow on the cartridge pointing upwards to the arrow on the mixer casting (eg. top face of casting).

**Fault 11.**

Unscrew the Diverter Clamp Nut on the bottom of the Mixer to access the Diverter Cartridge. (Insert a flat bladed screwdriver into one notch on the Diverter clamp nut and gently tap in an anti-clockwise direction to loosen the nut). Remove the diverter cartridge and replace as required. **Important**, the diverter cartridge should be in the **off** position when re-fitted. The **off** position of the Diverter cartridge has been marked at the factory with a black marked line across the top of the green Diverter housing and on one edge of the white Central diverter spindle. Ensure these lines align when refitting.

The Diverter cartridge can only be fitted in one way please ensure that the guide peg on the bottom of the cartridge locates into the single hole in the mixer casting. As a guide the single recessed line on the top of the diverter housing is positioned on the right and aligned with the Matki logo on the mixer casting. (b) Replace the Diverter Clamp nut, tighten the nut in a clockwise direction, the nut **can not** be overtightened, the nut will be flush to the mixer casting when tight.

7.PARTS LIST

5310CP

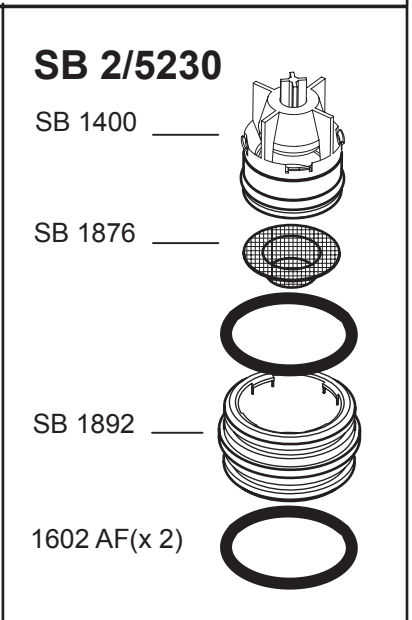
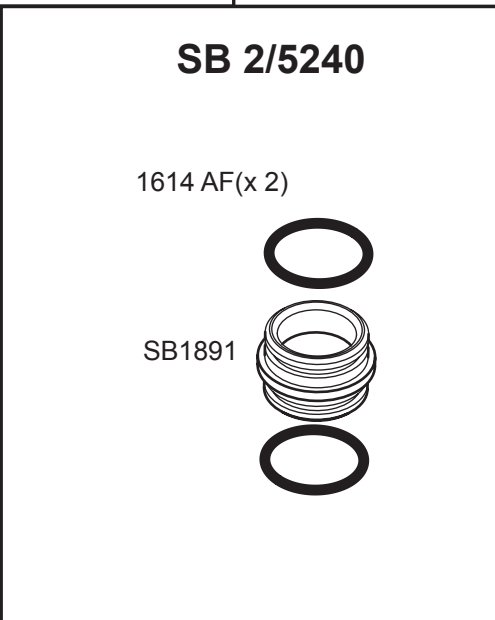
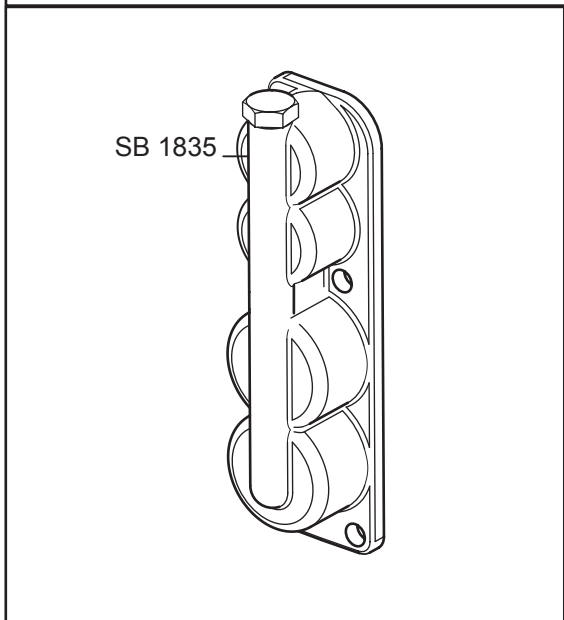
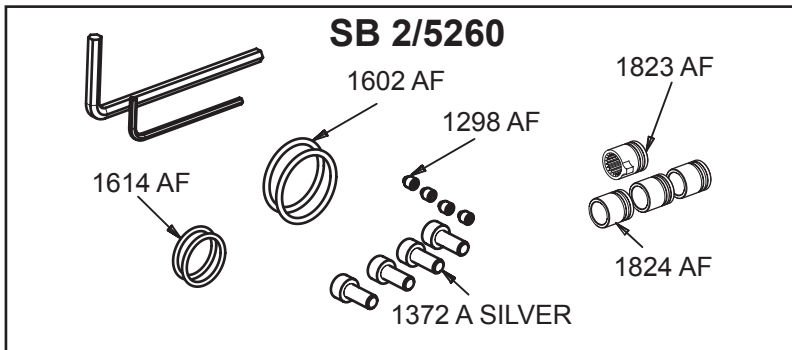
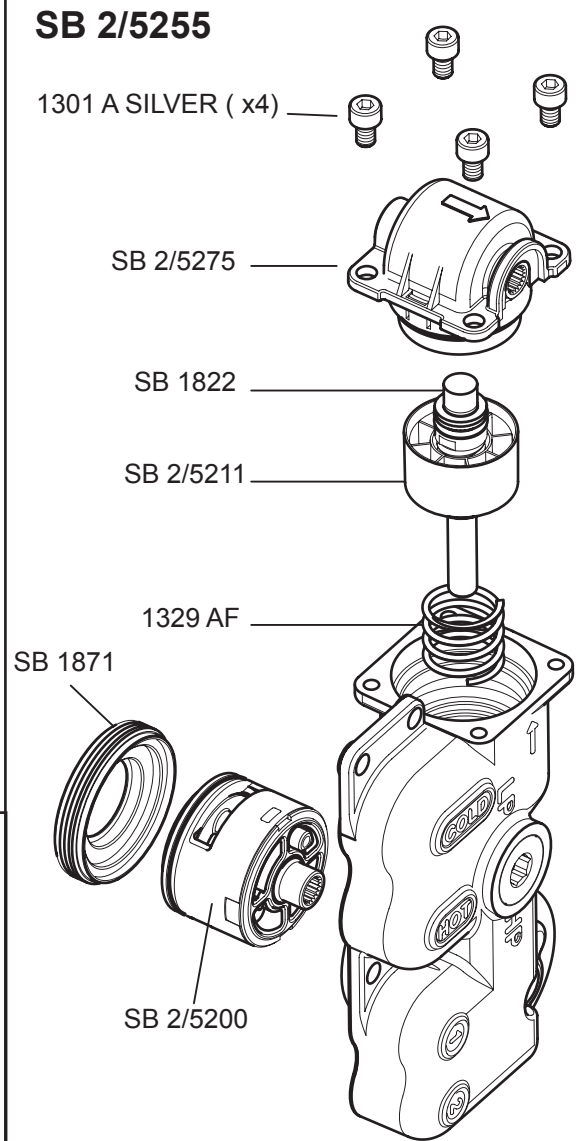
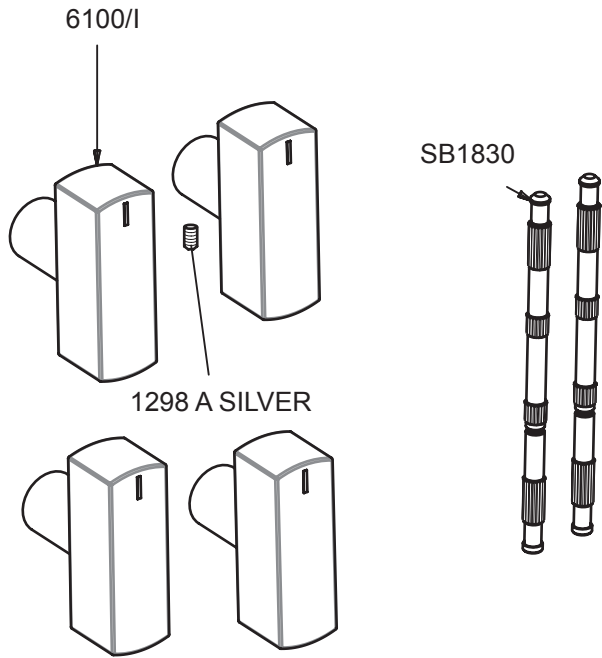

## FLOW RATES THERMOSTATIC VALVE ( FOR OPEN OUTLETS 1 & 2)

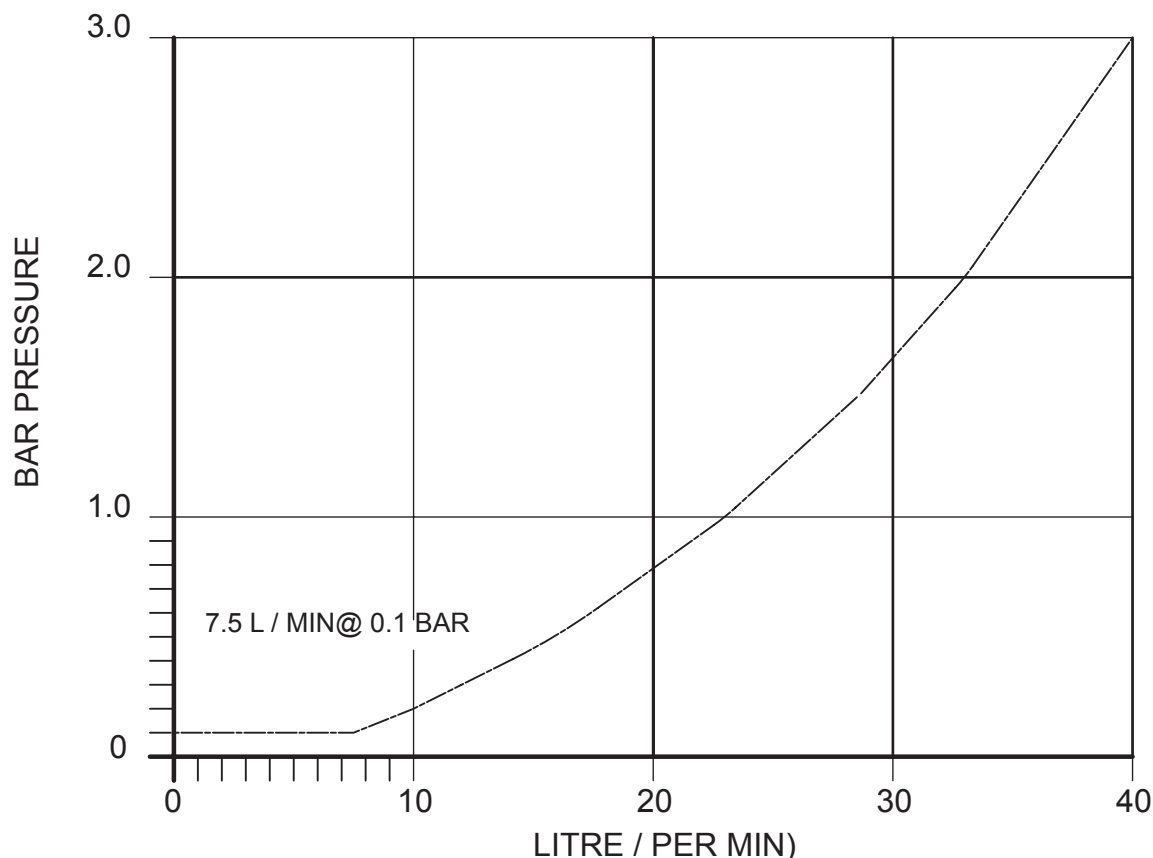

## CARE AND GUARANTEE

### Important care of your product

The controls and plate should be maintained by wiping with a soft, damp, clean cloth then polished using a dry duster.

**NO** abrasive powder, detergents or polishes should be used.

Cleaner containing alcohol, acid or corrosive chemicals should not be used.

**Note**, some household bleaches and denture cleaners can damage plated or coloured finishes and if splashed onto a fitting should be immediately washed off with cold water. If these instructions are followed we believe this fitting will give many years of satisfactory use.

We have a policy of continuous improvement and reserve the right to change specification without notice.

**Guarantee** - The Matki Elixir shower mixer is guaranteed for a period of 5 years against defects of materials and workmanship from date of purchase, subject to correct installation, maintenance and use in accordance with this instruction leaflet. Please retain proof of purchase. During the guarantee period parts will be replaced or repaired at our option.

No labour costs will be reimbursed unless prior agreement has been obtained from Matki Plc in writing.

This guarantee is offered as an extra benefit subject to registration and does not affect your statutory rights as a consumer in any way whatsoever.

**MATKI PLC, CHURCHWARD ROAD, YATE, BRISTOL, BS37 5PL**

TELEPHONE:01454 328816 (AFTER SALES) FAX:01454 328821 EMAIL:techsupport@matki.co.uk